

A NOVEL APPROACH TO SMART BLIND STICK USING ARDUINO UNO AND SENSOR

N. Naveen Kumar¹, N. Swathi², P. Akhila³, A. chandana⁴, M. Manoj Kumar⁵,
B. Soujanya⁶, O. Naga Venkata Sreya⁷

^{1,2}Assistant Professor of ECE Department, ^{3,4,5,6,7} UG Students of ECE Department
^{1,2,3,4,5,6,7}Anantha Lakshmi Institute of Technology and Sciences, Anantapur, Andhra Pradesh, India.

Abstract

This project proposes a Smart Blind Stick to assist visually impaired individuals in safely navigating their surroundings. The system integrates an Arduino Uno microcontroller, ultrasonic sensor, buzzer, vibrator, and LED. The ultrasonic sensor detects obstacles and relays this data to the Arduino Uno, which processes it and provides feedback through various outputs. The buzzer produces audible alerts, the vibrator offers tactile feedback, and the LED indicates obstacle proximity visually. This combination of components aims to enhance the independence and mobility of visually impaired users, ensuring safer and more efficient navigation.

Keywords

Smart Blind Stick, Arduino Uno, Ultrasonic Sensor, Visually Impaired, Buzzer, Vibrator, LED, Navigation Aid, Assistive Technology.

Introduction

The Smart Blind Stick provides visually impaired individuals with an efficient tool for safe navigation. Using an ultrasonic sensor, it detects obstacles and communicates them through various outputs such as a buzzer, vibrator, and LED. These components work together to create an affordable, easy-to-assemble, and portable device that enhances the independence of its users. The project leverages Arduino technology for processing and controlling the system.

Methods

Materials and tools

Arduino Uno R3: The Arduino Uno is an open-source microcontroller board based on the Microchip ATmega328P microcontroller (MCU) and developed by Arduino.cc and initially released in 2010. The microcontroller board is equipped with sets of digital and analog input/output (I/O) pins that may be interfaced to various expansion boards (shields) and other circuits.

Ultrasonic Sensor SR-04: The Ultrasonic Sensor is an electronic device which measures distances by sending out sound waves and collecting the returning echoes. It can measure items up to 4.5 meters away, making it a versatile tool for measuring both short and long distances accurately without contact with the target item - essential

in many applications such as obstacle avoidance systems in robotics or autonomous vehicles.

Buzzer: A buzzer, also known as a sounder, audio alarm, or audio indicator, is an audio signalling device that generates a sound from an electrical signal. Buzzers are used for many purposes, including alarms, timers, and confirming user input. They are used in household appliances, alarm systems, automatic production lines, low-voltage electrical equipment, electronic toys, and game machines.

Vibrator Motor: A mini vibrator motor is a small, compact device designed to produce vibrations when powered. These motors are commonly used in various applications such as mobile phones, wearable devices, toys, and small appliances. They typically consist of an eccentric rotating mass (ERM) or a linear resonant actuator (LRA) that generates vibrations when electricity is applied.

LED: LED, or Light Emitting Diode, is a semiconductor device that emits light when an electric current passes through it. It's a highly efficient and versatile lighting technology widely used in various applications. LEDs offer numerous advantages over traditional incandescent and fluorescent lights, including longer lifespan, lower energy consumption and smaller in the size

9V Battery and Connector: The 9V battery is an extremely common battery that was first used in transistor radios. It features a rectangular prism shape that utilizes a pair of snap connectors which are located at the top of the battery. A wide array of both large and small battery manufacturers produces versions of the 9V battery. Possible chemistries of primary (non rechargeable) 9V batteries include Alkaline, Carbon-Zinc (Heavy Duty), Lithium.

Jumper Wires: Jumper wires are electrical wires used to create temporary connections between electronic components on a breadboard or circuit board. They are typically made of flexible, insulated wire with connectors at each end, such as male-to-male, male-to-female, or female-to-female connectors. Jumper wires are commonly used in prototyping and experimenting with circuits, allowing for easy and quick adjustments or connections without the need for soldering.

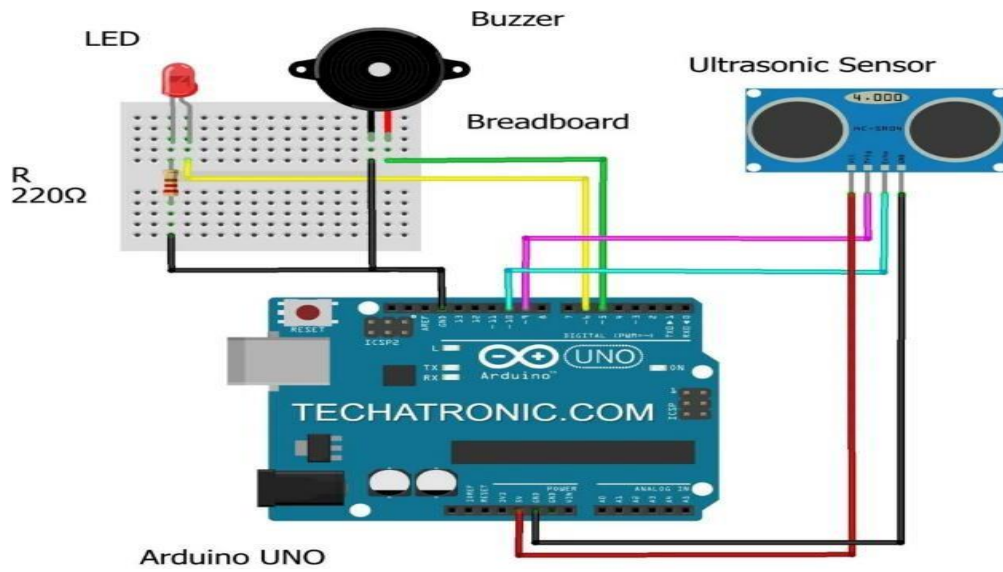

Fig 1:

Block Diagram of Smart Blind Stick Using Arduino Uno and Sensor

Procedure

1. Assembly

The ultrasonic sensor was connected to the Arduino's pins (VCC to 5V, Trig to pin 11, Echo to pin 12, GND to GND).

The LED was connected to pin 13 of the Arduino, and its cathode to GND.

The buzzer was connected to pin 9 (positive terminal) and GND (negative terminal).

The vibrator was connected to pin 10 (positive terminal) and GND (negative terminal)

2. Programming

An Arduino sketch was written to process the sensor's readings. When an obstacle is detected within a predefined range, the buzzer, vibrator, and LED are activated based on proximity to the object.

3. Testing

Obstacle detection and feedback responses were tested by placing various objects at different distances to ensure proper functionality of the ultrasonic sensor and the associated feedback mechanisms.

Working

Whenever the sensor detects any object in its path the buzzer starts beeping and also at the same time the LED turns on.

The blind person can hear the beeping of the buzzer and manage to change the way. In this way, the person can easily find his way without getting injured.

This smart stick works in the same way as the Ultrasonic range finder did. You can also see the real-time values of the distance in cm on the Arduino serial monitor.

Once the circuit is ready for this Arduino mini-project tie the whole set-up to a stick using zip ties.

Results

The Smart Blind Stick successfully detected obstacles within the range of 2-450 cm using the ultrasonic sensor. Based on the proximity to the obstacle, the buzzer emitted sound alerts, the vibrator motor generated haptic feedback, and the LED blinked to indicate obstacle presence. The device effectively responded to real-time inputs, offering visually impaired individuals assistance in identifying obstacles and navigating their surroundings safely.

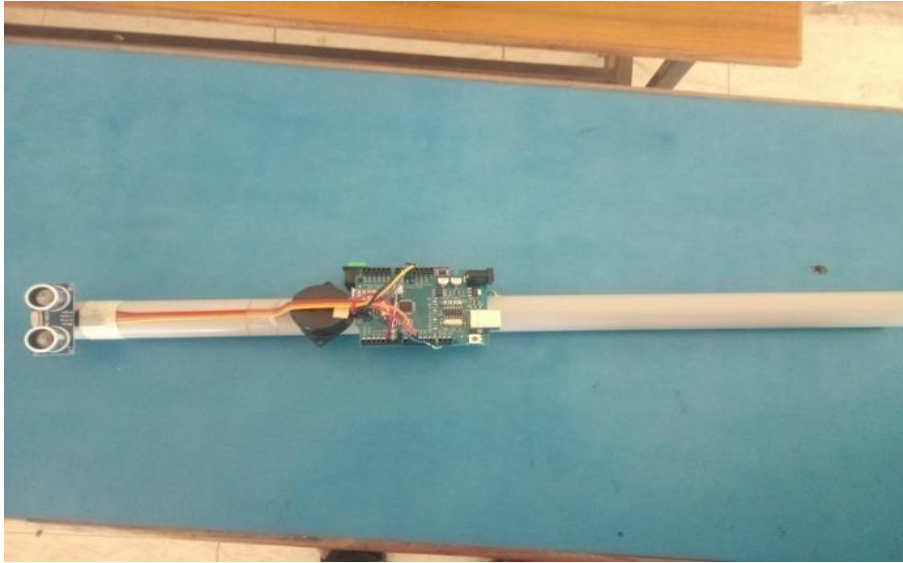

Fig 2: Smart Blind Stick Using Arduino Uno and Sensor

Discussion

The integration of multiple feedback mechanisms— auditory (buzzer), tactile (vibrator), and visual (LED) ensures comprehensive alerts for the user. The ultrasonic sensor's wide range and accurate measurements make the device highly functional. Future improvements could include GPS integration for broader navigation assistance, or the addition of Bluetooth for smartphone connectivity. The design also offers flexibility for further modification, including collapsibility or water resistance for durability in various conditions.

Conclusion

The Smart Blind Stick, designed using an Arduino Uno microcontroller, ultrasonic sensor, and various feedback mechanisms, provides a practical and effective solution for aiding visually impaired individuals. It offers real-time obstacle detection, helping enhance mobility and independence. This project demonstrates a cost-effective approach to assistive technology that could be further developed to improve the quality of life for visually impaired users.

References

- [1] R. Radhika, P.G. Pai, S. Rakshitha and R. Srinath "Implementation of Smart Stick for Obstacle Detection and Navigation." International Journal of Latest Research in Engineering and Technology, vol. 2, number 5, pp. 45-50, 2016.
- [2] Akhil, P.; Akshara, R.; Athira, R.; Kamalesh Kumar, S.P.; Thamootheran, M.; Shobha Christila, S. "Smart Blind Walking Stick with Integrated Sensor". Mater. Proc. 2022, 10, 12.
- [3] Madhumati Pol, Nandini Gaikwad, Omkar Gaikwad, Pratiksha Gaikwad, Shraddhey Gaikwad, Shreyas Gaikwad. "Smart stick for Blind people". Volume 10, Issue 12 December 2022.

[4] E. J. Chukwunazo and G. M. Onengiye "Design and Implementation of Microcontroller Based Mobility Aid for Visually Impaired People." International Journal of Science and Research. Vol. 5, issue 6, pp. 680-686, 2015.