

REAL-TIME REMOTE CONTROL AND MONITORING OF A WI-FI-CONNECTED CAR USING ESP32 AND IP-BASED CAMERA TECHNOLOGY

N. Naveen Kumar¹, T.G. Tejaswini², P. Sai Nikhitha³, S. Shabreen⁴, S. Jayavardhan⁵, U. Nageswari⁶, S. Amrutha⁷

^{1,2} Assistant Professor of ECE Department, ^{3,4,5,6,7} UG Students of ECE Department

^{1,2,3,4,5,6,7} Anantha Lakshmi Institute of Technology and Sciences, Ananthapuramu, Andhra Pradesh, India.

Abstract

Wi-Fi technology has revolutionized how we control devices remotely, offering low-power consumption options and vast potential in various fields. This project demonstrates the development of a Wi-Fi-controlled car, utilizing an ESP32 microcontroller, Node MCU, and L298N motor driver. The car connects to a local network and can be operated through a web interface hosted on the Node MCU, allowing for remote control via a mobile device. The project highlights the growing role of Wi-Fi in IoT (Internet of Things) applications and explores its potential in areas like surveillance, rescue missions, and navigating hazardous environments. It also incorporates an IP camera for real-time live streaming, enhancing remote control capabilities.

Keywords

Wi-Fi Controlled Car, ESP32, L298N Motor Driver, Internet of Things (IoT), Surveillance, Remote Control, Node MCU, DC Motor, Live Streaming, IP-based Webcam, Automation.

1. Introduction

The rapid advancement of Wi-Fi technology has significantly impacted how we interact with devices, particularly in the context of the Internet of Things (IoT). IoT has made it possible to control and monitor devices from anywhere, making tasks more convenient and efficient. This project showcases the development of a Wi-Fi-controlled car using an ESP32 microcontroller and L298N motor driver, enabling remote operation via a web interface hosted on the ESP32. The car can be controlled from any mobile device connected to the local Wi-Fi network, making it a practical example of IoT technology.

The primary goal of this project is to demonstrate the real-world applications of Wi-Fi and IoT by building a functional vehicle that can assist with tasks such as surveillance and rescue missions in areas that may be dangerous for humans to access. One of the standout features of this project is the incorporation of real-time video streaming, which allows users to receive live feedback for better control and monitoring of the car.

2. Methods

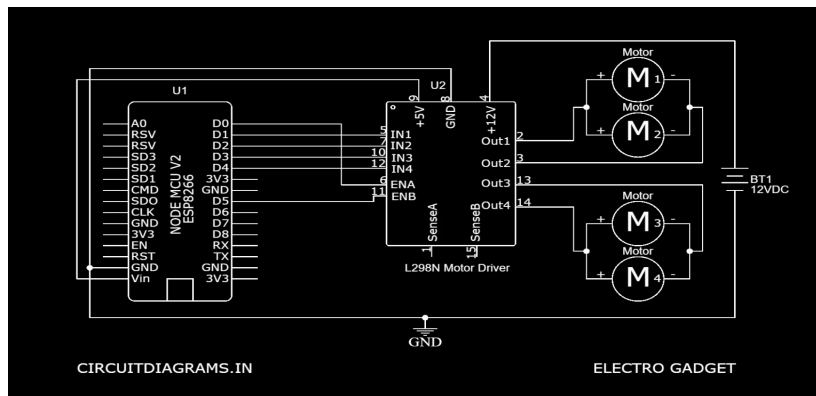

Fig a: Circuit Diagram

2.1 Components Used

- **ESP32 Module:** A powerful microcontroller with integrated Wi-Fi capabilities, used to control the car remotely.
- **L298N Motor Driver:** This module controls the speed and direction of the DC motors.
- **DC Gear Motors:** These motors provide propulsion to the car.
- **3.7V Lithium-ion Battery:** Powers the entire system, including the motors and microcontroller.
- **Jumper and Connecting Wires:** Essential for connecting various electrical components.

2.2 Procedure

Car Assembly:

The car chassis was equipped with DC motors, and wheels were attached to allow movement. A caster wheel was added for additional balance. The motors were connected to the L298N motor driver, which in turn was wired to the ESP32 microcontroller. Finally, the system was powered by a 3.7V lithium-ion battery, which supplied the necessary energy to the car's components.

Programming the ESP32:

The ESP32 microcontroller was programmed using the Arduino IDE. The code enabled the ESP32 to connect to the local Wi-Fi network and act as a web server, hosting a simple webpage. This webpage featured directional control buttons (forward, backward, left, and right) that allowed the user to control the car's movement.

Web Interface:

Once connected to the Wi-Fi network, the ESP32 generated a local IP address. By entering this IP address into a web browser on a mobile device or computer, users could access a control interface. The webpage displayed control buttons, allowing users to navigate the car by pressing the desired buttons.

Camera Integration:

An IP-based camera was incorporated to provide a live video feed. This camera streamed video footage through the same web interface, enabling users to view real-time video of the car's surroundings and enhance remote navigation.

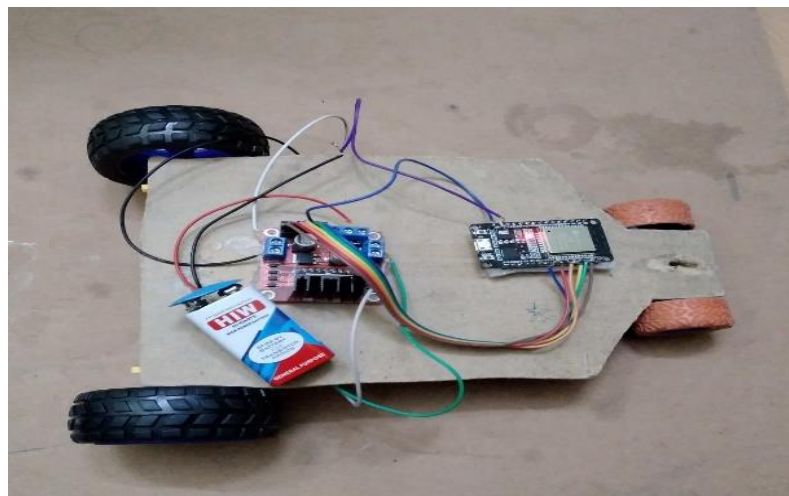

Fig b: Experimental Setup

3. Result

The Wi-Fi-controlled car performed as expected, accurately responding to navigation commands sent from the mobile device through the web interface. The L298N motor driver provided precise control of the motors, ensuring smooth movement in all directions. Additionally, the IP camera streamed reliable real-time video, allowing for seamless remote operation. The web interface was easily accessible from any device connected to the same Wi-Fi network, making it simple for users to control the car and view the live feed.

4. Discussion

This project effectively demonstrates how IoT and Wi-Fi technology can be applied to create a functional, remotely controlled vehicle. By using the ESP32 microcontroller, the car could be navigated wirelessly within a local Wi-Fi network, allowing flexible control. The addition of a live-streaming IP camera expanded the car's capabilities, making it suitable for applications such as surveillance, rescue missions, and monitoring hazardous environments.

The project has immense potential for improvement. Adding GPS functionality could enable real-time location tracking, making it easier to follow the car's movements even in large areas. The camera could be upgraded for higher resolution, improving video quality for clearer monitoring. Furthermore, by integrating cloud services, the car could be controlled beyond the local network, significantly expanding its range. The versatility of this system suggests it could be applied in numerous fields, including security, wildlife monitoring, and disaster response.

5. Conclusion

This project successfully demonstrates how Wi-Fi technology can be harnessed to develop remotely controlled systems. The Wi-Fi-controlled car, equipped with an ESP32 microcontroller and L298N motor driver, showcased effective real-time navigation and live video streaming, making it an ideal example of IoT in action. Future developments could include GPS integration and enhanced video streaming capabilities, allowing the system to be used in even more sophisticated applications. Overall, the project serves as a practical demonstration of the role IoT can play in developing remote surveillance systems with diverse uses.

6. References

- [1] Kim M., Kang K.C., Lee H. Formal Verification of Robot Movements - a Case Study on Home Service Robot SHR100. In the Proceedings of the IEEE International Conference on Robotics and Automation (ICRA), 4739-4744p, 2005.
- [2]<http://www.electronicshub.org/remoteoperated-spy-robot-circuit>
- [3] Taipalus T., Kazuhiro K. Development of service robot for fetching objects in home environment. In the Proceedings of the IEEE International Symposium on Computational Intelligence in Robotics and Automation (CIRA), 451-456p, 2005.
- [4] Perotoni M.B., Garibello B.E., Barbin S.E. Low-Cost Planner Antenna for a Mobile Robot. IEEE802.11, 2006
- [5] JIovine J. PIC Robotics: A beginner's guide to robotics projects using the PIC micro. McGraw-Hill, 2004.