

A NOVEL APPROACH TO WATER QUALITY MONITORING SYSTEM

N. Naveen Kumar¹, K. Sajida², P.Varsha³, K.Sowmya⁴, S. Yesaswari Bai⁵,

J. Mahima Reddy⁶

^{1,2}Assistant Professor of ECE Department, ^{3,4,5,6} UG Students of ECE Department

^{1,2,3,4,5,6} Anantha Lakshmi Institute of Technology and Sciences, Ananthapuramu, Andhra Pradesh, India.

Abstract

Ensuring access to clean and safe water is critical for public health and environmental sustainability. Real-time water quality monitoring is essential for early detection of contaminants. This study presents a low- cost, portable water quality monitoring system using the Arduino Uno microcontroller. The system integrates sensors to measure key water quality parameters including turbidity, temperature, and dissolved oxygen levels. The Arduino Uno serves as the central processing unit, enabling data acquisition from the sensors and managing overall system operation. The system's affordability, portability, and ease of use make it suitable for deployment in various environments, including drinking water sources, wastewater treatment facilities, and natural water bodies. This project highlights the feasibility of using Arduino Uno for cost-effective and efficient water quality monitoring, contributing to the broader goal of ensuring safe and clean water resources.

Keywords:

Water Quality Monitoring, Arduino Uno, Turbidity Sensor, I2C LCD Module, RGB Module, Real-Time Monitoring, Portable System

Introduction

In an era of heightened environmental awareness, the quality of water bodies has become a focal point for researchers and communities. Ensuring the safety of water for drinking, recreation, and ecosystem support is crucial. Traditional water quality monitoring methods are often complex and expensive, limiting their accessibility, particularly in remote or resource- constrained areas. The Arduino Uno, an affordable and versatile microcontroller, has transformed environmental sensing. With its user-friendly interface and extensive community support, Arduino Uno is ideal for developing customizable and cost-effective water quality monitoring systems. By integrating Arduino with sensors designed to measure water quality parameters such as turbidity, this project aims to create a practical tool for monitoring various aspects of water quality. The system offers a solution for assessing water safety, pollution levels, and aquatic health, making it an empowering tool for local water resource management.

Methods:

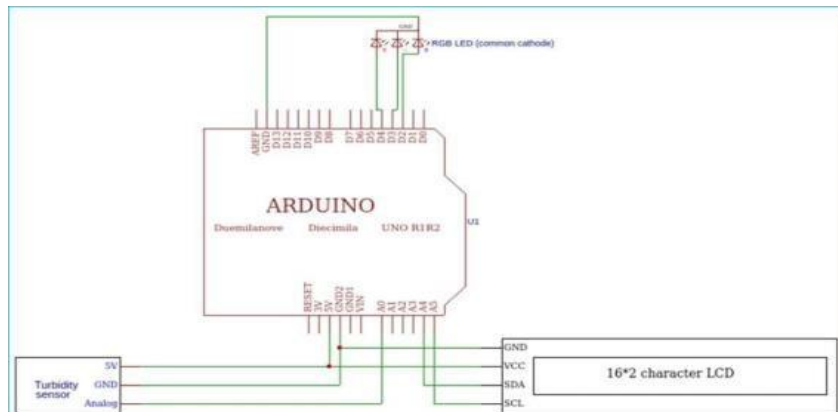

Fig 1: Block Diagram of Monitoring System

1. Components Used:

Arduino Uno: The microcontroller board that processes sensor data and controls the overall system operation.

Turbidity Sensor Module: Measures the clarity of water by detecting the amount of light that passes through the water.

I2C LCD Module: An LCD with an I2C interface that simplifies wiring and displays real-time data from the sensors.

RGB Module: An LED module that combines red, green, and blue light to create various colors, used for visual feedback.

Breadboard: A platform used for prototyping the circuit, allowing components to be connected without soldering.

9V Battery: Provides power to the Arduino and sensors.

Jumper Wires: Used for making connections between the components on the breadboard.

2. Experimental Setup:

To set up the water quality monitoring system, start by powering the Arduino Uno using a 9V battery or USB cable. Connect the turbidity sensor's analog output to pin A0 on the Arduino, with its VCC and GND linked to the Arduino's 5V and GND pins, respectively. Similarly, its VCC and GND to the Arduino's 5V and GND pins.

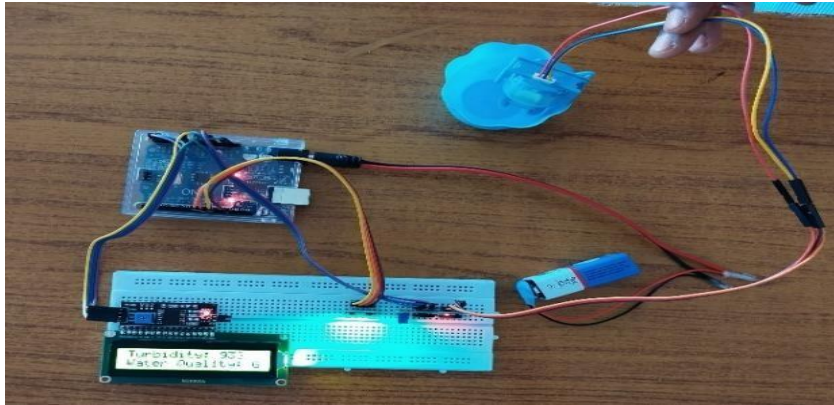

Fig 2: Experimental Setup

Attach the I2C LCD module by connecting SDA to A4, SCL to A5, VCC to 5V, and GND to GND. Optionally, connect the RGB module's RGB pins to digital pins D3, D5, and D6, and its common cathode/anode to GND or 5V. Arrange all components on a breadboard and use jumper wires to make the necessary connections. Upload the Arduino code to handle sensor readings and display data on the LCD. Power on the system, check the connections, and calibrate the sensors to ensure accurate measurements.

Result

The water quality monitoring system using the Arduino Uno performed effectively in assessing key water quality parameters. The turbidity sensor provided accurate readings of water clarity, reflecting changes in contamination levels with data shown on the LCD. The LCD module displayed real-time data clearly, and the RGB module, when used, provided visual indicators of water quality. The system's performance was stable, with accurate readings and minimal deviations post-calibration. Overall, the setup demonstrated a reliable and cost-effective solution for real-time water quality monitoring.

Discussion

The water quality monitoring system using Arduino Uno effectively demonstrated its capability to measure and display crucial water parameters such as turbidity. The system's accuracy in detecting turbidity levels showed its potential for monitoring water contamination in real-time. The LCD module facilitated clear and immediate data presentation, enhancing usability. The RGB module offered an additional layer of visual feedback, useful for quick assessments. Despite its affordability and simplicity, the system's performance was robust, making it a practical tool for various water quality monitoring applications.

Conclusion

The Arduino-based water quality monitoring system successfully achieved its objectives of providing real-time, accurate assessments of water parameters. The integration of turbidity sensors allowed for comprehensive water quality analysis. The I2C LCD module effectively displayed critical data, ensuring ease of use and readability. The system's affordability, portability, and reliable performance demonstrate its potential for widespread application in both field and laboratory

settings. While the current setup provides valuable insights, future enhancements could focus on sensor calibration, expanding sensor types, and incorporating IoT connectivity for remote monitoring. Overall, this system represents a significant advancement in accessible water quality monitoring technology.

References

1. World Health Organization (WHO). (2021). Guidelines for Drinking-water Quality. Retrieved from <https://www.who.int/publications/i/item/9789240062070>
2. Arduino Project Hub. (n.d.). Water Quality Monitoring with Arduino. Retrieved from <https://create.arduino.cc/projecthub>
3. "Water Quality Monitoring and Management" by S. K. Gupta Book covering various aspects of water quality monitoring and management from <https://link.springer.com/book/9789811626103>
4. Libelium., "Water Quality Monitoring in Europe's Largest Fluvial Aquarium", Retrieved from Libelium: <http://www.libelium.com/water-quality-monitoring-europe-largest-fluvial-aquarium-zaragoza/>, Accessed on: November 4, 2015.
5. S. Garuglieri, D. Madeo, A. Pozzebon, R. Zingone, C. Mocenni and D. Bertoni, An Integrated System for RealTime Water Monitoring Based on Low Cost Unmanned Surface Vehicles. In 2019 IEEE Sensors Applications Symposium, Sophia Antipolis, France, 11-13 March 2019, pp.
6. Cloete, N., Nair, L., & Malekian, R. (2016, January). Design of Smart Sensors for Real-Time Water Quality Monitoring. Retrieved February [rt_Sensors_for_Real-Time_Water_Quality_Monitoring.pp](#).