

# AN AUTOMATIC HOME CONTROL SYSTEM USING SOUND TECHNOLOGY

Dr. Y.L. Ajay Kumar<sup>1</sup>, Y. Nirmala<sup>2</sup>, G. S. Joya Tabassum<sup>3</sup>, S.Mahaboobjan<sup>4</sup>, M. Ayesha Banu<sup>5</sup>, R. Divya<sup>6</sup>, K. Vasanthi<sup>7</sup>

<sup>1</sup>Professor of ECE Department, <sup>2</sup>Assistant Professor of ECE Department, <sup>3,4,5,6,7</sup> UG Students of ECE Department

<sup>1,2,3,4,5,6,7</sup>Anantha Lakshmi Institute of Technology and Sciences, Anantapur, Andhra Pradesh, India.

## Abstract

This project presents an innovative automatic home control system utilizing sound technology to manage household appliances. The system enables users to control devices such as lights, fans, and other electrical equipment through sound commands, specifically claps or voice cues. By incorporating a microphone for sound detection, a sound sensor for differentiating relevant commands from background noise, and a microcontroller for processing, the system translates sound signals into control actions. This approach provides a convenient, hands-free solution that enhances accessibility, particularly for individuals with limited mobility. The project demonstrates the effectiveness of sound-based control in smart home environments and highlights areas for future development, including improved accuracy and integration with advanced voice recognition technologies.

## Keywords:

Sound Technology, Home Automation, Clap Switch, Smart Home Control, Sound-Based Control System, Microcontroller, Sound Sensor, Hands-Free Operation, Accessibility, Voice Activation, Electrical Appliances

## Introduction

In the modern era, the pursuit of more intuitive and accessible home automation solutions has become increasingly prevalent. Traditional methods of controlling household appliances often involve physical interaction, which can be cumbersome or inaccessible for some users. To address these limitations, this project explores the use of sound technology as a means of automating home control. By harnessing sound signals, such as claps or voice commands, this system allows users to manage devices like lights, fans, and other electrical appliances with ease.

Sound-based control systems leverage the simplicity and universality of sound cues to provide a hands-free and user-friendly interface for home automation. The core of the system consists of a microphone for capturing sound, a sound sensor to distinguish between different sound patterns, and a microcontroller to process these signals and execute corresponding commands. This technology not only enhances convenience and accessibility but also offers a cost-effective alternative to more complex smart home.

## Methods:

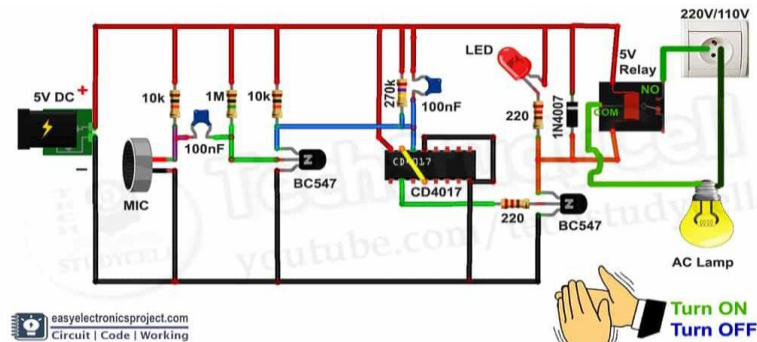

**Fig 1: Circuit Diagram of Automatic home control system using sound Technology**

### 1. Components Used:

**CD4017 IC :** It is a CMOS decade counter IC that sequentially activates one of its 10 output pins with each clock pulse, often used in digital counting and sequencing applications.

**BC547 NPN transistors:** It is used for switching and amplification in electronic circuits, with a low current rating and moderate voltage handling capabilities.

**1N4007 Diode:** It is a rectifier diode capable of handling up to 1000V and 1A, commonly used for converting AC to DC in power supply circuits.

**Resistors (10k,270k,1M,220Ω) :** These limit or regulate the flow of electric current in a circuit by providing resistance.

**Capacitor (100nf):** It stores and releases electrical energy in a circuit, typically used for filtering, timing, and energy storage applications.

**LED :** It emits light when an electric current passes through it.

**Bread Board:** It is a platform for prototyping electronic circuits, allowing components to be inserted and connected without soldering.

**Connecting Wires:** Essential for connecting various electrical components.

### 2. Experimental Setup:

System Assembly:

**Connect Components:** Assemble the components on a breadboard . Ensure all connections are secure and correct, including power supply connections to the microphone, sound sensor, and relay modules.

Power Supply:

Provide an appropriate power source for the entire system, ensuring that it meets the voltage and current requirements of each component.

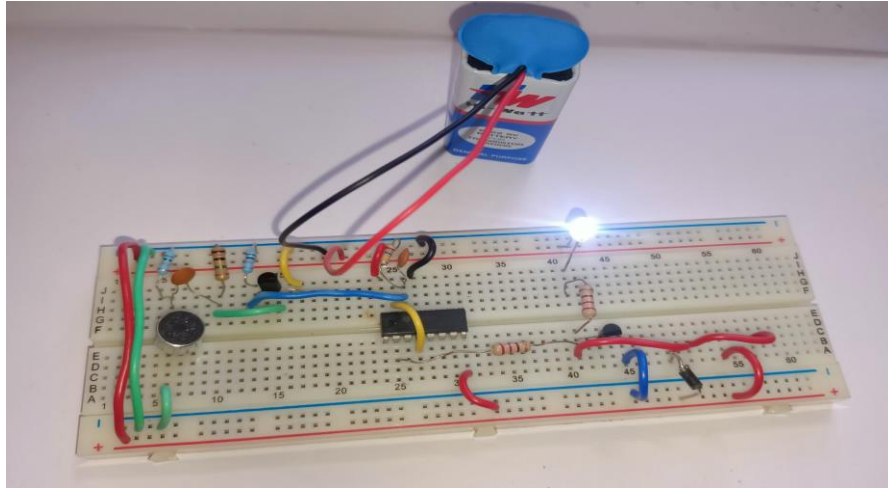

**Fig 2: Experimental Setup**

Integrate a microphone to capture sound signals. Connect the microphone to a sound sensor circuit designed to detect and filter sound patterns such as claps or voice commands.

Connect the relay circuits to the household appliances. Verify that each appliance responds correctly to the sound commands.

Working:

At first, the clap sound sensed by the condenser mic.

The condenser mic converts the sound into an electric pulse.

Then the electric pulse amplified by the BC547 transistor.

After that, the electrical pulse fed to the CLK pin of CD4017 IC.

For each high pulse at CLK pin the state of the PIN 2 changes.

When the PIN 2 becomes HIGH, the second transistor turns ON.

Now when the condenser senses the second clap sound, the next high pulse received at CLK PIN.

The PIN 2 changed the state (becomes LOW), so the second transistor turns OFF.

### **Result**

The implementation of the automatic home control system using sound technology yielded promising results. The system successfully detected and responded to specific sound commands, such as claps, to control household appliances, demonstrating its capability to turn devices on and off with a high degree of reliability. The response time was generally satisfactory, with appliances activating or deactivating within a few seconds of the detected sound command. However, this response time occasionally varied based on the sound sensor's sensitivity and the ambient noise level.

### **Discussion**

This project effectively demonstrates the implementation of an automatic home control system using sound technology presents several benefits and challenges. This

approach leverages sound signals, such as claps or voice commands, to operate household appliances, making it particularly advantageous for users seeking hands-free control or those with limited physical mobility.

Benefits: The ability to control devices through simple sound commands enhances user convenience and simplifies interaction with home appliances. Sound-based controls offer an inclusive solution for individuals with physical disabilities, providing an alternative to traditional manual switches or touch-based controls. Utilizing sound sensors and basic electronic components can be a low-cost solution compared to other smart home systems.

Future Directions :Enhancing signal processing algorithms and integrating advanced noise-cancellation techniques could improve accuracy and reliability. Incorporating more sophisticated voice recognition technology could expand the system's functionality, allowing for more complex commands and broader control options. Connecting the sound-based control system with existing smart home platforms could enhance its versatility and enable seamless interaction with other smart devices

Overall, while the sound-based home control system offers a promising and accessible solution, ongoing development and refinement are necessary to address its limitations and fully realize its potential in modern smart home environments.

## **Conclusion**

This project successfully demonstrates the automatic home control system utilizing sound technology demonstrates an innovative approach to managing household devices through sound cues like claps or voice commands. This system enhances user convenience and accessibility by offering a hands-free, intuitive method for controlling appliances. Its implementation showcases the potential of sound-based control in smart home environments and highlights opportunities for further advancements in accuracy, responsiveness, and integration with other smart technologies.

## **References**

1. Home Automation Systems - A Study. April (2015)International Journal of Computer Applications .  
[https://www.researchgate.net/publication/275338025\\_Home\\_Automation\\_Systems\\_-\\_A\\_Study](https://www.researchgate.net/publication/275338025_Home_Automation_Systems_-_A_Study)
2. Sound-Based Control System Used in Home Automation  
January 2018Lecture Notes in Electrical Engineering .In book: Computational Signal Processing and Analysis (pp.267-278).  
[https://www.researchgate.net/publication/324159705\\_Sound-Based\\_Control\\_System\\_Used\\_in\\_Home\\_Automation](https://www.researchgate.net/publication/324159705_Sound-Based_Control_System_Used_in_Home_Automation)
3. Home Automation Control System  
by IRJET journal  
[https://www.academia.edu/89843466/Home\\_Automation\\_Control\\_System](https://www.academia.edu/89843466/Home_Automation_Control_System)

#### 4. Secure and Smart Home Automation System with Speech Recognition

By Chandra Irugalbandara 1,2, Abdul Salam Naseem 1, Sasmitha Perera 1, Sithamparanathan Kiruthikan 1 and Velmanickam Logeeshan 1,\*ORCID

<https://www.mdpi.com/1424-8220/23/13/5784>